

Dr. D. Francisco Hernández Altemir	Fray Luís Amigó, 8 Planta 0, letra B
Doctor en Medicina y Cirugía	5005 Zaragoza
Estomatólogo	Colegiado Médico 505004161
Cirujano Oral y Maxilofacial	Teléfono 976270719
Titulado en Pediatría y Puericultura	<a href="mailto:drhernandezaltemir@yahoo.es">drhernandezaltemir@yahoo.es</a>
Titulado en Cirugía Plástica y Reparadora	<a href="mailto:shmendodoncia@gmail.com">shmendodoncia@gmail.com</a>
Titulado en Traumatología y Ortopedia	<a href="http://www.headandneck.es">www.headandneck.es</a> (profesional)
	<a href="http://www.medicinavcirujiaoralymaxilofacial.info">http://www.medicinavcirujiaoralymaxilofacial.info</a> (científica)

15 August, 2024 Zaragoza, Spain

To the attention of Ms. Ursula Von der Leyen, President of the European Commission,

With this letter we would like to bring to your attention the following development in the area of sports.

It consists of a New Tennis Racket that can reach additional length during the game. We believe that this design may be relevant for a new tennis type, with great potential for diverse needs players.

I include the corresponding patent information and copy the link to the television program when it was first shown.

<https://www.youtube.com/watch?v=nqBQkDtwGgo&feature=youtu.be>

It was also shown at the "Salon International des Inventions" in Geneva, Switzerland, in 2001. The award certificate is included in this letter for reference.

I would like to know your opinion about this design, its potential uses, and contact information for a follow up.

Thank you very much for considering.

With my warmest regards,

Dr. F. Hernández Altemir

Kind regards,



15/8/2024  
Dr. Francisco Hernández Altemir.  
CIRUGIA ORAL Y MAXILOFACIAL  
D.N.I. 310.593-F • Colegiado nº 4191  
Fray Luís Amigó, 8, Planta, 0, Letra B  
Tel. 976 270 719 • Fax 976 387 553  
50006 ZARAGOZA

Dr. Francisco Hernández Altemir, Col. 505004161

Corresponding Academic of the Royal Academy of Medicine in Zaragoza

# DIPLÔME



## SALON INTERNATIONAL DES INVENTIONS GENÈVE

Appareil, le jeu inventif a été  
déposé par **FRANCISCO HERNANDEZ ALTERIS**  
pour l'invention: **DISPOSITIF pour l'extension des raquettes.**  
**UNE MEDAILLE D'ARGENT** Genève le 8 avril 2001

à l'adresse: **Club  
Tennis de Genève**

### less effort

by playing tennis

#### BALL-RETRIVING DEVICE FOR TENNIS RACQUETS AND RACQUETS

A device for retrieving balls from the top of your racket without the need to change to another racket. The ball returns to the racket when it passes the racket and does not fall out of the racket when it passes the racket.

It is a device for retrieving balls from the top of your racket without the need to change to another racket. The ball returns to the racket when it passes the racket and does not fall out of the racket when it passes the racket.



Geneve  
4-5  
April  
2001



### new tennis

#### ADJUSTABLE DEVICE FOR TENNIS RACQUETS AND TENNIS RACQUETS

The new device for tennis racquets is a device for adjusting the racket to the player's hand. The device is a device for adjusting the racket to the player's hand.

The device is a device for adjusting the racket to the player's hand. The device is a device for adjusting the racket to the player's hand.



Geneve  
4-5  
April  
2001







Europäisches Patentamt  
European Patent Office  
Office européen des brevets



(11) EP 1 208 877 A1

(12) EUROPEAN PATENT APPLICATION

(43) Date of publication:  
29.05.2002 Bulletin 2002/22

(51) Int Cl.7: A63B 47/00, A63B 47/02,  
A63B 49/00, A63B 49/02

(21) Application number: 01500253.8

(22) Date of filing: 23.10.2001

(84) Designated Contracting States:  
AT BE CH CY DE DK ES FI FR GB GR IE IT LI LU  
MC NL PT SE TR  
Designated Extension States:  
AL LT LV MK RO SI

(72) Inventor: Hernandez Altemir, Francisco  
50006 Zaragoza (ES)

(74) Representative: Cobas Horcajo, Susana  
Propi, S.L.,  
Jorge Juan, 19  
28001 Madrid (ES)

(30) Priority: 24.11.2000 ES 200002887

(71) Applicant: Francisco Hernandez Altemir, S.L.  
50006 Zaragoza (ES)

(54) Improved ball collecting device for racquets and bats

(57) Improved ball collecting device for racquets and bats having swinging arms (7,8) aided by their respective springs (9), preferably fitted on swinging hinges (6) on an anchoring base (1), springs (9) which cause the aforementioned arms (7,8) to be permanently folded over the anchoring base (1), the arms (7,8) being activated remotely, from the area of the handgrip (3) of the bat or racquet, by means of at least one transmission wire (17), aided by the corresponding casing (18), which

connects the swinging arms (7,8) with a lever (10), in turn fixed in a way that it can move back and forth on the body of the bat or racquet, in the area of the handgrip (3), in a way which the manual action on the lever (10) causes the pincers, made up of the two arms (7,8), to open in order to pick up the ball, pressing against the springs (9) which cause the pincers to automatically close on releasing the manual pressure on the aforementioned lever (10).

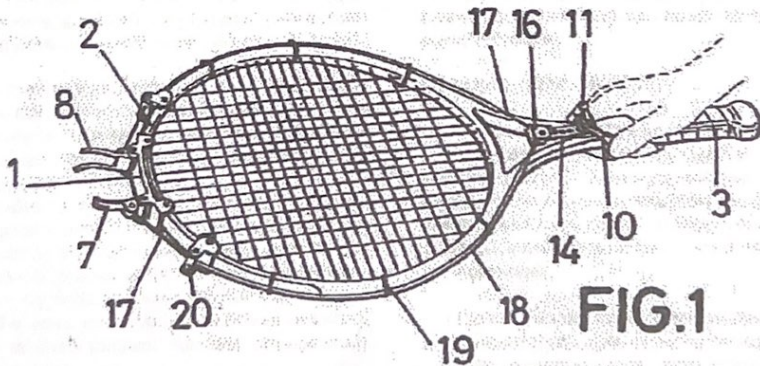

EP 1 208 877 A1



**Description****OBJECT OF THE INVENTION**

[0001] The invention herein refers to a ball collecting device which has been specially conceived as an accessory for a tennis racquet or any other type of racquet or bat used in various types of games, where such bats and racquets are used to hit a ball.

[0002] The object of the invention is to make the action of collecting balls from the floor or ground much easier.

**BACKGROUND OF THE INVENTION**

[0003] In the type of games previously mentioned, in which a racquet or bat is used to hit a ball, the players are constantly having to pick the balls up from the floor which, apart from being uncomfortable, means an additional exercise, and an important consumption of energy, which reduces the player's performance in the course of the game. Although certain manoeuvres can be resorted to, to avoid momentarily bending down to pick up the ball, such as making it bounce on the ground by hitting it with the edge of the racquet or bat, this action is also uncomfortable, notably wastes time and ends up causing damage to the bat or racquet, which sometimes hits the ground or floor directly.

[0004] In an attempt to avoid this problem, the same applicant is holder of the Utility Model Application No. 9902258, which refers to a ball collecting device for racquets and bats, consisting of an anchoring base, with a means of being connected to the edge of the bat or racquet, in any suitable place, such as the opposite end to the grip or shaft, the ends of the base being connected by a hinge to a pair of swinging arms which form a type of pincer of suitable dimensions to hold a ball, under slight pressure, allowing it to be lifted with the bat or racquet itself and avoiding the need for the body to be bent over.

[0005] The swinging nature of the aforementioned arms has the obvious function of allowing them to be folded on the anchoring base, under normal game conditions, so as not to cause an obstacle which would make playing more difficult.

[0006] Although this solution has adequate features from the point of view of collecting balls, a basic problem is presented by the fact that each time a ball has to be picked up it is also necessary to extend the swinging arms manually, and a second and further manoeuvre of closing the arms, once the ball has been retrieved, means a relatively complex, slow and uncomfortable manoeuvre.

**DESCRIPTION OF THE INVENTION**

[0007] The ball collecting device which the invention proposes, based on the functional philosophy of the Util-

ity Model previously mentioned, completely solves the inherent problem of the latter.

[0008] To be more specific, based again on the use of a pair of swinging arms in the form of pincers, the main characteristics of the device are that the arms are in a permanently closed position due to their respective springs, preferably fixed on the hinge, the arms being remotely activated, from the grip or shaft of the bat or racquet, by means of a small lever which pulls on at least one wire that transmits the movement of the aforementioned lever to the arms, causing the pincers to open.

[0009] In this way, by simply pressing on the lever the device adopts the position required for receiving the ball, which fits perfectly between the swinging arms once the lever is released, due to the springs returning to their original position.

[0010] Thus, not only is it possible to achieve outstanding agility in the manoeuvre of picking up the ball, but a better grip of the ball as the spring action, when the pincers of the device are closed, avoids grip problems due to possible looseness in the aforementioned arms or any other cause.

[0011] Preferably, two wires will be used and activated simultaneously by the same lever and connected to the respective arms of the pincers, which will run along the corresponding edges of the bat or racquet, suitably fitted in their respective casings and properly joined to the outer edges of the bat or racquet.

[0012] In accordance with another of the characteristics of the invention, it is proposed that one of the arms of the pincers takes the form of a curved finger, and the other the form of a fork, also curved with suitably distanced arms, which makes it doubly effective, on the one hand a better grip of the ball, sitting between the arms of the fork and held down against the latter by the opposite finger, and on the other hand when folded away, i.e. when the device is not in use, the finger is situated between the arms of the fork, taking up the minimum amount of space.

**DESCRIPTION OF DRAWINGS**

[0013] To complement the above description and with the aim of offering a greater understanding of the invention's characteristics, in accordance with a preferred example of practical embodiment of the same, a set of illustrative and non-restrictive drawings are attached as an integral part of this description, in which the following are represented:

Figure 1.- Shows, from a view in perspective, a tennis racquet with a ball collecting device incorporated in accordance with the improvements which are the object of the present invention, in which the lever of the device is shown when activated and, consequently, the pincers for gripping the ball are open.

Figure 2.- Shows a partial detail in perspective of the racquet in the previous figure, in the area of the



activating lever of the mechanism, now in the inactive position.

Figure 3.- Finally, shows another enlarged detail in perspective of the racquet in Figure 1, this time in the area of the pincers, which hold the ball, and also in an inactive position.

#### PREFERRED EMBODIMENT OF THE INVENTION

[0014] In the light of the figures described, it can be observed how the device which the invention proposes is made up of an anchoring base (1), which in the practical embodiment example of the figures, is fixed to the frame (2) of the racquet on the opposite side to the handgrip (3), but which can equally adopt any other position which is deemed adequate, e.g. by using outer lugs (4) which clasp the aforementioned frame (2) and which are connected to the same by means of pins or screws (5). On either end of the aforementioned anchoring base (1), a transversal hinge (6) that allows a swinging movement is fitted for each corresponding arm (7-8), each of the hinges (6) aided by a helical spring (9) which causes the arms (7) and (8) to swing into a folded position on the anchoring base (1), as shown in Figure 3.

[0015] One of the aforementioned arms, that which is marked (7), consists of a curved finger, while the other arm (8) takes the form of a fork, also curved, which can be seen particularly clearly in Figure 1, to facilitate the grip of the ball between the pincers made up of the aforementioned arms (7) and (8).

[0016] These arms (7) and (8) are activated simultaneously from the lever (10) which is fitted using a hinge (11), to allow a swinging movement, on a mounting (12) which has a means of connecting to the racquet in the area of the handgrip (3), a lever (10) which in mid-position and by means of an articulated hinge (13) receives a bracket (14) which by means of a hinge (15) also receives an articulated connecting element (16); by means of studs or any other means, for the ends of two wires (17) which, incorporated in their corresponding casings (18), run along the outer edges of the frame (2) of the racquet, fixed by means of, e.g. elastic rings (19), the aforementioned casings (18) each being finished off with stoppers (20), also connected to the frame (2) of the racquet in the area of the anchoring base (1) and from which the wires (17) are positioned towards the respective arms (7) and (8), which are suitably fixed to the outside of the articulated hinge (6).

[0017] In accordance with the structure described and from the mechanism's inactive position shown in Figures 2 and 3, in which the pincers (7-8) remain closed, by simply pressing with one's finger on the lever (10), as shown in Figure 1, this produces traction on the arms (7) and (8) which then adopt an open position as shown in Figure 1, with which the ball is easily picked up from the ground, and after picking it up, by simply releasing or ceasing the action on the lever (10) the device automatically returns to the inactive position shown in Fig-

ures 2 and 3, due to the action of the springs (9), to then enable the game being played to continue.

[0018] Optionally, the two wires (17) can be substituted by a single wire, obviously with a transmission system of any conventional type which allows the simultaneous action of the two arms (7) and (8) of the pincers, instead of the aforementioned rings (19) for fixing the covering or housing of the wires any other means can be used, the composition of the arms (7) and (8) can also vary in accordance with any design criteria, and the manual action of the lever (10) described can be substituted by an electrical, hydraulic or pneumatic impulse without obviously affecting the essence of the invention.

#### Claims

1. Improved ball collecting device for racquets and bats, with an end to momentarily picking up the ball from the ground on the edge of the racquet or bat, to then be raised by this element to the player's hand level, and being of the type which incorporates a pair of swinging arms, fitted on an anchoring base which can be connected to any area of the edge of the bat or racquet, characterised in that the aforementioned swinging arms (7,8) are aided by their respective springs (9), preferably fitted on their articulated hinges (6) on the anchoring base (1), springs (9) which cause the aforementioned arms (7,8) to remain folded at all times on the anchoring base (1), the arms (7,8) being able to be activated remotely, from the area of the grip (3) of the bat or racquet, by means of at least one transmission wire (17), together with the corresponding casing (18), which connect the swinging arms (7,8) with a lever (10) or similar, which is fitted in a way that it can move back and forth on the body of the bat or racquet, in the aforementioned area of the handgrip (3), so that the manual action on the aforementioned lever (10) causes the pincers made by the two arms (7,8) to open in order to pick the ball up, pressing against the respective springs (9), causing the aforementioned pincers to close automatically on ceasing the manual action on the aforementioned lever (10).
2. Improved ball collecting device for racquets and bats, in accordance with claim 1, characterised in that it includes preferably two wires (17), with their corresponding casings (18), duly connected to the outer edges of the bat or racquet, by any suitable means (19), which are connected to the arms (7,8) on the outside of their articulated hinges (6) which in turn are fixed, on their opposing end, to an anchoring element (16) articulately fixed to a bracket (14) which in turn is articulately fixed to the middle part of the manually activated lever (10), i.e. between the swinging hinge (11) on the body of the

racquet and the manually activated end.

3. Improved ball collecting device for racquets and bats, in accordance with the previous claims, characterised in that one of the arms (7) which make up the pincers, takes the form of a curved finger and the other (8) takes the form of a fork, also curved, for the ball to fit perfectly between the aforementioned arms (7,8).

5

10

15

20

25

30

35

40

45

50

55

4



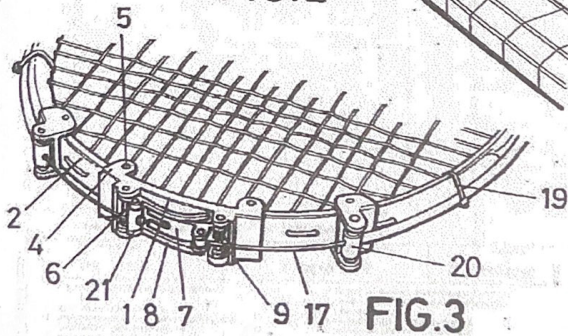
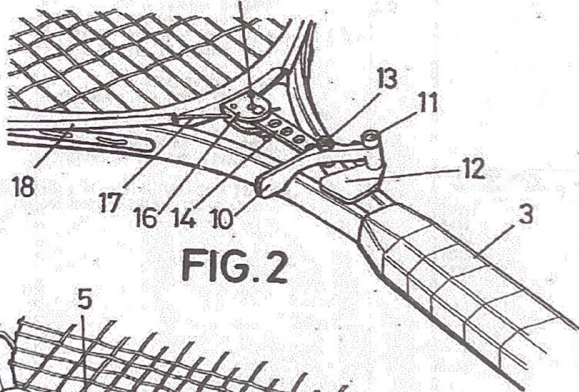
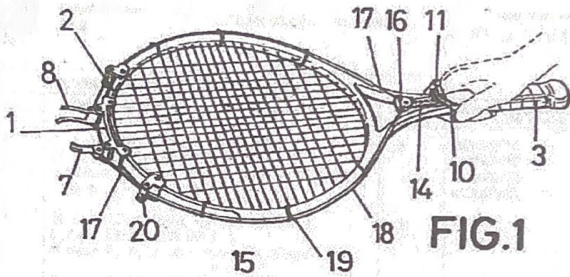

European Patent  
Office

## EUROPEAN SEARCH REPORT

Application Number  
EP 01 50 0253

DOCUMENTS CONSIDERED TO BE RELEVANT			
Category	Citation of document with indication, where appropriate, of relevant passages	Relevant to claim	CLASSIFICATION OF THE APPLICATION (Int. Cl.7)
A	US 5 383 651 A (BECK ANDREW L) 24 January 1995 (1995-01-24) * column 2, line 48 - column 3, line 24; figures 1-4 *	1,3	A63B47/00 A63B47/02 A63B49/00 A63B49/02
A	GB 412 707 A (ERIC LESLIE MICHELL) 5 July 1934 (1934-07-05) * page 1, line 59 - line 97; figure 1 *	1,3	
A	FR 2 591 497 A (GALLEE BERNARD) 19 June 1987 (1987-06-19) * page 2, line 15 - line 18; figures 3,5 * * page 2, line 28 - line 32 *	1,3	
A	US 3 989 247 A (ZIPPERMAN ELI) 2 November 1976 (1976-11-02) * column 1, line 34 - line 38; figures 1-12 * * column 1, line 62 - column 2, line 10 * * column 2, line 37 - line 59 *	1	
A	FR 1 457 651 A (BALLET & FILS A) 24 January 1966 (1966-01-24)		TECHNICAL FIELDS SEARCHED (Int. Cl.7)  A63B A47F B25J A01B E01H
The present search report has been drawn up for all claims			
Place of search <b>THE HAGUE</b>		Date of completion of the search <b>5 March 2002</b>	Examiner <b>Oelschläger, H</b>
CATEGORY OF CITED DOCUMENTS			
X : particularly relevant if taken alone Y : particularly relevant if combined with another document of the same category A : technological background O : non-written disclosure P : intermediate document T : theory or principle underlying the invention E : earlier patent document, but published on, or after the filing date D : document cited in the application I : document cited for other reasons A : member of the same patent family, corresponding document			



EP 1 208 877 A1

**ANNEX TO THE EUROPEAN SEARCH REPORT  
ON EUROPEAN PATENT APPLICATION NO.**

EP 01 50 0253

This annex lists the patent family members arising in the patent documents cited in the above-mentioned European search report. The members are as contained in the European Patent Office EDP file on The European Patent Office is in no way liable for these particulars which are merely given for the purpose of information.

05-03-2002

Patent document cited in search report		Publication date	Patent family member(s)	Publication date
US 5383661	A	24-01-1995	NONE	
GB 412707	A	05-07-1934	NONE	
FR 2591497	A	19-06-1987	FR 2591497 A1	19-06-1987
US 3989247	A	02-11-1976	NONE	
FR 1457651	A	24-01-1966	NONE	

EPIC FORM 1478E

For more details about this annex : see Official Journal of the European Patent Office, No. 12/82

Dear Sir,

Please find attached a letter from Ms Florencia van Houdt, Head of the Sport Unit in Directorate General for Education, Youth, Sport and Culture, to your attention.

Best regards,

Sport Unit

European Commission  
Directorate-General for Education, Youth, Sport and Culture  
Unit D3 – Sport  
B-1049 Brussels / Belgium  
[http://ec.europa.eu/sport/index\\_en.htm](http://ec.europa.eu/sport/index_en.htm)





EUROPEAN COMMISSION  
DIRECTORATE-GENERAL FOR EDUCATION, YOUTH, SPORT AND CULTURE  
Culture, Creativity and Sport  
Sport

Brussels  
EAC.D.3/MZ

Dr Francisco Altemir Hernandez  
Fray Luis Amigó, 8 Planta 0, letra  
5006 Zaragoza  
Spain

By e-mail:  
drhernandezaltemir@yahoo.es

**Subject: New tennis racket**

Dear Sir,

Many thanks for your letter of 15<sup>th</sup> August to President Ursula von der Leyen who asked me to reply on her behalf.

It was very interesting to read about the innovative tennis racket you designed.

However, given the autonomy of sport to decide on its own rules, the European Commission has no competence in proposing or imposing new rules or instruments in the practice of sport.

My suggestion is to get in touch with the International Tennis Federation (<https://www.itftennis.com/en/>) which is the governing body of world tennis.

Yours faithfully,

Florencia VAN HOUDT  
Head of Unit

Commission européenne/Europese Commissie, 1049 Bruxelles/Brussel, BELGIQUE/BELGIË – Tel. +32 22991111  
Office: J-70 02/283 – Tel. direct line +32 229-91289

Matteo.Zacchetti@ec.europa.eu

Electronically signed on 30/08/2024 17:11 (UTC+02) in accordance with Article 11 of Commission Decision (EU) 2021/2121